

IMPROVED CONDITIONS FOR MEASUREMENT OF THE SPECIFIC HEAT CAPACITIES OF PURE TRIGLYCERIDES BY DIFFERENTIAL SCANNING CALORIMETRY

N. A. Morad, M. Idrees and A. A. Hasan

Lipids Applied Science and Engineering Research (L.A.S.E.R.), Department of Chemical Engineering, Universiti Teknologi Malaysia, Jalan Semarak, Kuala Lumpur, 54100 Malaysia

(Received May 29, 1994; in revised form September 2, 1994)

Abstract

Reproducible specific heat capacities (C_p) of triglycerides can be obtained by using heat-flux DSC under improved operating conditions. The improved operating parameters, such as the scanning rate, the sample mass and the atmosphere within the DSC chamber, were established via statistical analysis of the experimental data with trilaurin as a sample. The specific heat capacity results on trilaurin were compared with the values calculated by using estimation methods. The precision of the specific heat capacity measured for trilaurin under these conditions was within $\pm 1\%$.

Keywords: DSC, improved conditions, specific heat capacity, statistical analysis, triglycerides

Introduction

Specific heat capacities determined by DSC have been found to depend considerably on the conditions of the experiment (e.g. scan rate and purging) and also on the mass of sample taken. This affects the reproducibility of the results. It was found necessary to determine the best DSC operating conditions so that errors and variations should be minimized.

Instrumental effects may cause serious errors in specific heat capacity measurements by DSC. These effects, which have been observed by a number of authors, should be corrected and incorporated into the experimental procedure where possible. Suzuki and Wunderlich [1] pointed out the three major causes of error: a) incompatible thermal histories of the sample, reference and blank; b) unstable initial and final isotherms; and c) incompatible differences between the initial and final isotherm amplitudes for sample, reference and blank runs. Hatakeyama *et al.* [2] confirmed the difficulty of attaining stable isotherms be-

fore and after experimental runs, as reported by five different participants who measured the specific heat capacity of polystyrene. Brennan *et al.* [3] attributed the unstable initial and final isotherms to the differences in radiation characteristics in measurements of specific heat capacities of cotton and poly(methyl-methacrylate).

Apart from instrumental effects, operating parameters such as scan speed, sample mass and gas purging play important roles in the reliability of specific heat capacity measurements. The effects of scan speed have been discussed [3–6]. In the measurement of specific heat capacities of solids such as sapphire [5], clinoptilolite and dolomite [4] by means of heat-flux DSC, for instance, scan speeds of 0.5–10 deg·min⁻¹ have been suggested. Specific heat capacities of polymers have been measured with scan speeds of 5–20 deg·min⁻¹ [2, 3, 5]. Phillips and Matammal [7] and Hampson and Rothbar [8] used power-compensated DSC to measure the specific heat capacities of simple triglycerides at a scan speed of 10 deg·min⁻¹.

The effect of sample mass on the reproducibility of specific heat capacity measurements was discussed in [4, 5, 9]. The thermal conductivity of the sample in the pan also influences the reproducibility and in turn affects the correct amount of sample, as pointed out by Schawe and Schick [10]. It was found that, for a fixed scan rate, a temperature gradient is built up within samples of low thermal conductivity and this is further enhanced by an increased mass of sample.

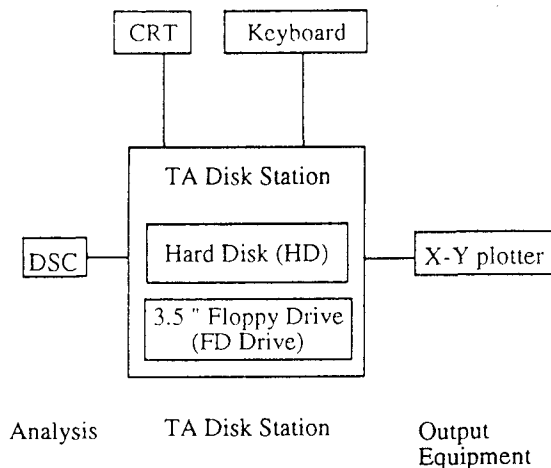

Fig. 1 The block diagram of the Seiko heat-flux DSC system

The improved conditions in the present work were found by taking the maximum possible experimental precautions necessary to eliminate the instrumental effects and to optimize the operating parameters. The effects that cause non-re-

producibility of measurements can be reduced considerably, if not eliminated completely.

Experimental

Equipment

The specific heat capacity measurements were made with the Seiko heat-flux DSC system, which comprises a DSC 220 furnace, a data-processing unit TA station, an output device for recording the hard copy and a visual display unit. Figure 1 shows the block diagram of the Seiko heat-flux DSC model.

Sample

Trilaurin was purchased from Sigma Chemical Co. and was more than 99% pure.

Principle of specific heat capacity measurement by DSC

The specific heat capacity, C_{ps} , of a substance, measured by DSC, is given by

$$C_{ps} = \frac{Y_s M_r C_{pr}}{Y_r M_s} \quad (1)$$

where Y is the deflection from the baseline, M is the mass, and C_p is the specific heat capacity, while subscripts r and s refer to the reference material and sample, respectively.

Procedure

The round robin test (RRT) was used for the specific heat capacity measurements, as described by Hatakeyama *et al.* [2], and the Seiko Instrumentation Manual [11].

Results and discussion

Various statistical measures are necessary since the results obtained were not completely reproducible. Statistical test were used to establish whether the observed effects were real ones due to the parameters or the result of random experimental fluctuations. In view of the strictly observed experimental precautions and the great effort taken, a confidence level of 95% is used on the regressed data.

Improved scan rate

Extreme care was taken to maintain identical experimental conditions for the blank, reference and sample runs, or at least to minimize the changes in the experimental conditions. However, this did not give results of perfect reproducibility. Due to the random nature of the results, the data were analysed statistically, by using linear regression methodology. It is assumed that the specific heat capacity varies linearly with temperature throughout the range of interest (the results of individual experiments show that this is a valid assumption).

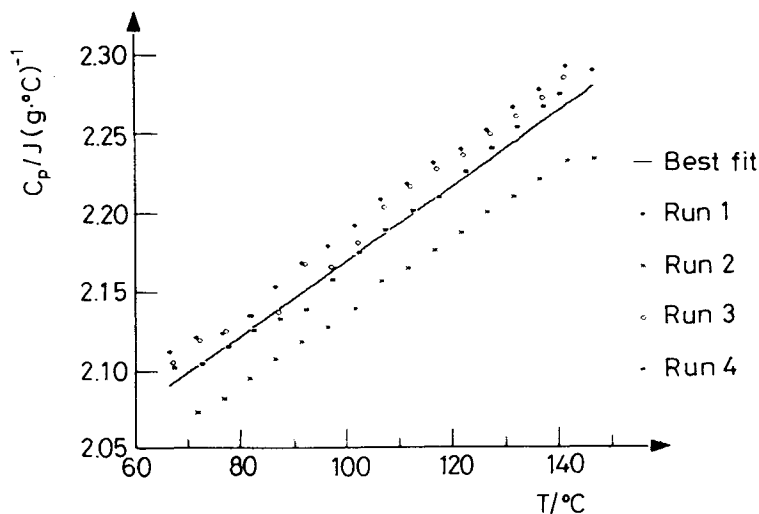

Fig. 2 Specific heat capacity of trilaurein as a function of temperature at scan rate $17 \text{ deg}\cdot\text{min}^{-1}$, sample weight: 21 mg, and no purge gas. Four different runs under the same conditions

The experiments were conducted at scan rates of 6, 10, 15, 17, 20 and $23 \text{ deg}\cdot\text{min}^{-1}$. Four runs were performed at each scan rate in the temperature range 50 to 150°C . The sample mass was kept constant at 21 mg and no purge gas was used. For all scan rates, the experimental data were linearly regressed using the least squares method to give the best fit, as shown in Fig. 2.

Naturally, we would like to know whether the linear regression model tentatively assumed is correct. This requires determination of the lack of fit test for each set (four runs) of experimental data. The objective is to break down the error of the sum of squares (SS_e) into two components, one due to pure error, and one due to the lack of fit. The sum of pure error (SS_{pe}) includes uncontrollable factors in the experiment, such as instrumental effects. The sum of the lack of fit (SS_{lof}) is therefore the difference between the error in the sum of squares and

the sum of the pure error. If the value calculated in the F -test is below the critical F value (F -distribution tables), then the model assumed is correct.

In addition to the lack of fit test, another statistic, the standard deviation, σ , was used to measure the dispersion of the experimental data for each scan rate. The scan rate which gives the lowest standard deviation is favoured, since this indicates a smaller scatter in the data. The statistical analysis of the data is explained in more detail in Appendix.

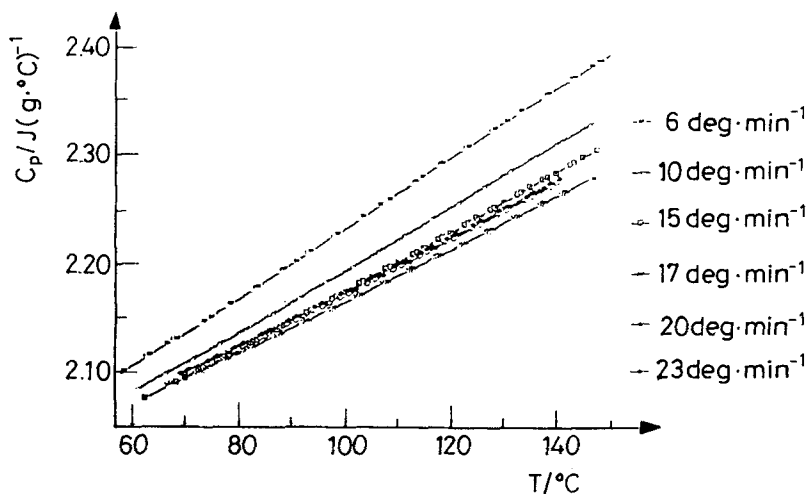

Fig. 3 Specific heat capacity of trilaurin as a function of temperature at various scan rates (sample weight: 21 mg, no purge gas)

It was found that all the scan rates satisfy the F -test statistic, which automatically indicates that the linear regression model is appropriate. Low standard deviation values were given by scan rates of 17 deg·min⁻¹ ($\sigma=0.0590$), 20 deg·min⁻¹ ($\sigma=0.0540$) and 23 deg·min⁻¹ ($\sigma=0.0606$). The statistical results suggests that the scan rate of 17 deg·min⁻¹, which has low standard deviation and F_0 values, is the best scan rate, and it was therefore used in the subsequent experiments. Figure 3 shows the variation in the specific heat capacity of trilaurin at different scan rates, while the variation in the standard deviation with the scan rate is illustrated in Fig. 4.

Improved sample mass

The sample mass is implicitly related to the scanning rate. Perhaps each scanning rate has an optimum sample mass. To find the best sample mass, the experiments were conducted at the optimum scan rate of 17 deg·min⁻¹. All other conditions, such as the temperature range from 50 to 150°C and the atmosphere, were maintained similar to those for the determination of the improved

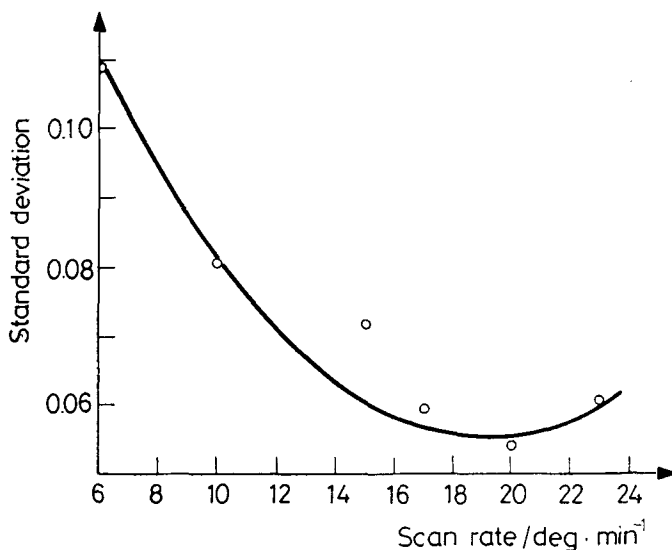

Fig. 4 Effect of scan rate on the standard deviation of specific heat capacity values obtained for trilaurin, sample weight: 21 mg, no nitrogen flow

scan rate. The sample masses were 10, 16, 21, 25 and 35 ± 0.5 mg, respectively. Four replicate runs were performed for each constant sample mass.

The method of determining the best sample mass was similar to that for determining the best scan rate. It was found that all the sample masses satisfy the *F*-test statistic, indicating that the linear regression model is appropriate. Low standard deviations were given by sample masses of 21 mg ($\sigma=0.0590$), 25 mg ($\sigma=0.0583$) and 35 mg ($\sigma=0.0635$).

The results of specific heat capacity measurements on various sample masses are shown in Fig. 5, which also gives the two specific heat capacity values calculated for trilaurin by using the estimation methods of Phillips and Mat-tamal [7]. A comparison of the experimental results (21 mg) with the calculated values shows that they have similar slopes. Thus, it can be concluded that the specific heat capacity value calculated with a sample mass of 21 mg is nearest to the estimated value. Figure 6 illustrates the variation in the standard deviation with variation of the sample mass.

Incidentally, the choice of 21 mg (about half the maximum capacity) as sample mass is also proposed by the manufacturer for the open sample pan used here. However, this is in contrast with the view of Xichiro *et al.* [9], who suggested that as much sample as possible should be used in specific heat capacity determinations by DSC.

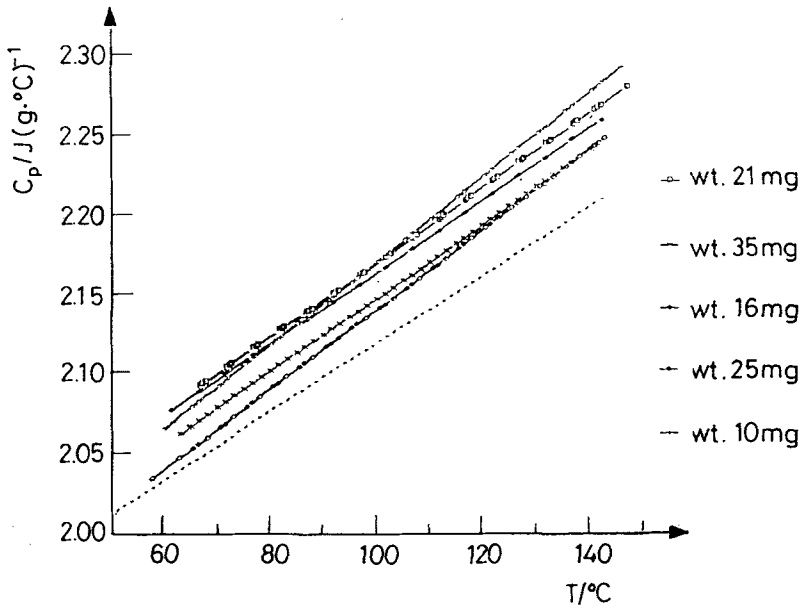

Fig. 5 Specific heat capacity of trilaurin as a function of temperature: effect of sample weight; wt.: sample weight; est. = estimation method of C_p , Phillips and Mattamal (1978)

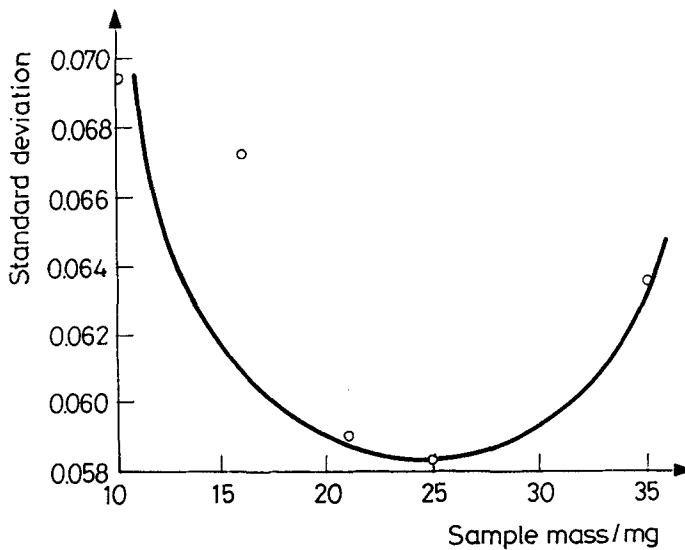

Fig. 6 Effect of sample weight on the standard deviation of specific heat capacity values obtained for trilaurin, scan rate: $17 \text{ deg} \cdot \text{min}^{-1}$ and no purge gas flow

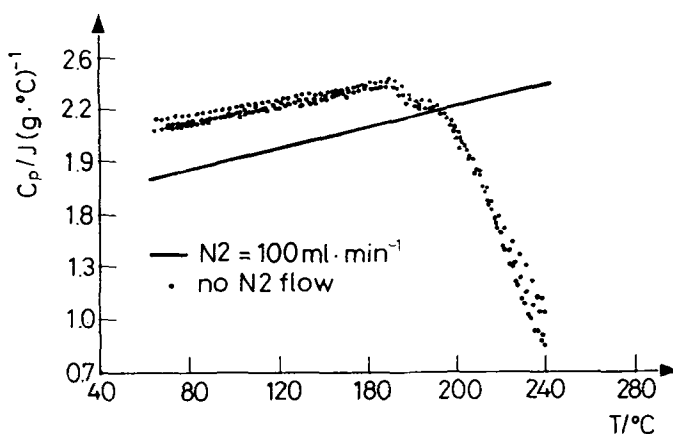

Fig. 7 Specific heat capacity of trilaurin as a function of temperature: effect of N_2 flow in the cell; indicates degradation of sample when no purge gas is used

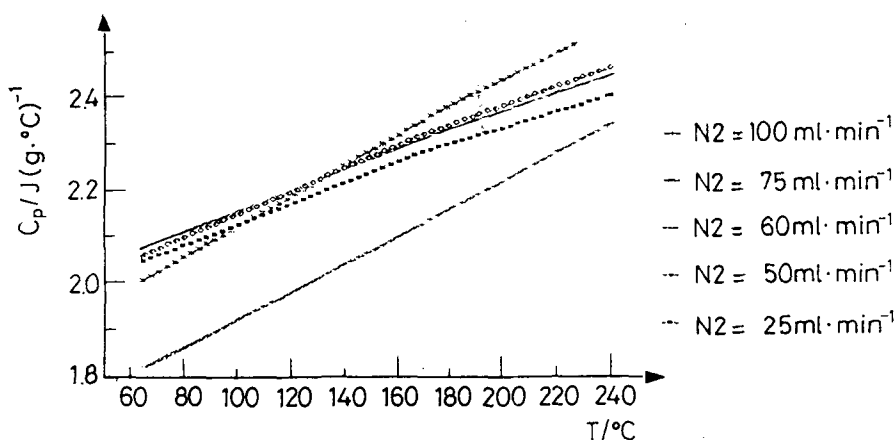

Fig. 8 Specific heat capacity of trilaurin as a function of flow of nitrogen through the cell (solid lines represent lower temperature range (50–170°C), dashed lines higher temperature range (180–250°C))

Improved nitrogen flow

It is desirable to have specific heat capacity data beyond 150 °C, up to approximately 250°C. Processes such as 'deodorization' in palm-oil refineries operate at temperatures in the range of 200 to 250°C. Specific heat capacities in this range are therefore of great industrial importance. The temperature range in the previous experiment was fixed from 50 to 150°C. The lower temperature corresponds to the melting point of trilaurin, and the higher temperature to the

onset of degradation. Figure 7 shows results of specific heat capacity measurements conducted beyond 150°C. The sudden drop in specific heat capacity indicates the onset of degradation of trilaurin.

As with the scan rates and sample masses, variation of the nitrogen flow rate contributes to the reproducibility of specific heat capacity results. The presence of a gas flow may lower the furnace temperature and cause a lag between the sample and holder temperatures [5]. However, if a small flow of nitrogen is introduced into the chamber as a purge gas during the scanning, degradation can be reduced, if not eliminated. This degradation is obviously due to the presence of oxygen from the air and the high temperature. The use of an inert gas purge to protect an unencapsulated sample has been recommended [12]. Hampson and Rothbar [8] also used nitrogen in determination of the specific heat capacities of triglycerides. The optimum flow rate for the purge gas was determined in experiments conducted at five different flow rates of nitrogen: 25, 50, 60, 75 and 100 ml·min⁻¹. The scan rate and sample mass were kept at the improved values determined earlier: 17 deg·min⁻¹ and 21 mg respectively. The temperature range was from 50 to 250°C.

The specific heat capacity of trilaurin with variation of the nitrogen flow rate is illustrated in Fig. 8. The improved nitrogen flow rate was found by using the same statistical methods as employed previously. Even though the nitrogen flow lessens degradation of the sample, there is a definite change in the slope for all the nitrogen flow rates from the first part of the curve (<170°C) to the second (170 to 250°C). This indicates changes within the sample above the degradation point, even in the presence of nitrogen as a purge gas.

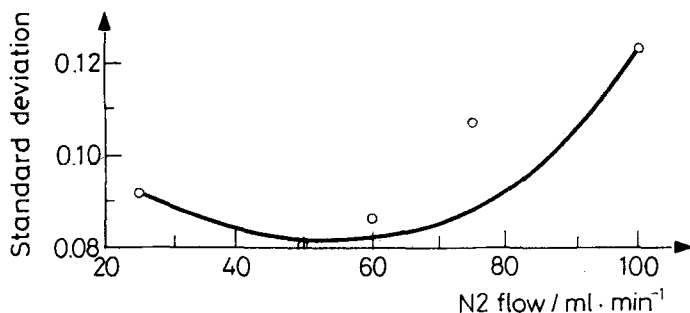

Fig. 9 Effect of purge gas flow (nitrogen) on the standard deviation of the specific heat capacity values obtained for trilaurin, scan rate: 17 deg·min⁻¹, sample weight: 21 mg

The improved nitrogen flow rate should be chosen so that the variation in the regressed slope of the first portion (50–170°C) from the regressed slope of the second portion (170–250°C) is minimal. This is to ensure that minimum degradation of the sample takes place at elevated temperatures. Even though the re-

sults at a nitrogen flow rate of $100 \text{ ml}\cdot\text{min}^{-1}$ show the least variation between the first and second slopes, the specific heat capacity is very much lowered from that without nitrogen.

Low standard deviations were found for nitrogen flow rates of $50 \text{ ml}\cdot\text{min}^{-1}$ ($\sigma=0.0797$) and $60 \text{ ml}\cdot\text{min}^{-1}$ ($\sigma=0.0863$). With regard to the *F*-test, $50 \text{ ml}\cdot\text{min}^{-1}$ was chosen as the best nitrogen flow rate. The variation in the standard deviation with the nitrogen flow rate is shown in Fig. 9.

Conclusions

The reproducibility of specific heat capacities determined by heat-flux DSC depends on many conditions: scan rates, sample masses, gas purging and sample pan type. Other factors that are not discussed here but which contribute to discrepancies in the results are the sample pan material and the pan positioning. Reproducible specific heat capacity results can be obtained by running experiments under improved parameters conditions. For triglycerides, with trilaurin as sample, these conditions have been found to be a scan rate of $17 \text{ deg}\cdot\text{min}^{-1}$, a sample mass of 21 mg, and a purge gas flow rate of $50 \text{ ml}\cdot\text{min}^{-1}$. Under these conditions, reproducible specific heat capacities of triglycerides can be obtained within a precision of $\pm 1\%$ with DSC up to 220°C .

* * *

The authors wish to express their appreciation to MIMOS for the DSC equipment, to the Government of Malaysia for a research grant, and to members of L.A.S.E.R. for their support and co-operation.

Symbols

C_p	heat capacity at constant pressure in J/mole deg
<i>F</i> -test	statistical analysis to check whether the assumed linear regression model is valid
<i>M</i>	mass of the reference substance/sample in mg
MS_e	error or residual mean square, a statistical term
MS_{lof}	mean square lack of fit, a statistical term (Eq. A4)
MS_{pe}	mean square pure error, a statistical term (Eq. A4)
<i>n</i>	no. of observations used in statistical analysis
S_{xx}	corrected sum of squares of <i>x</i> , a statistical term (Eq. A5)
SS_e	error sum of square, a statistical term (Eq. A2)
SS_{lof}	sum of squares of lack of fit, a statistical term (Eq. A2)
SS_{pe}	sum of squares of pure error, a statistical term (Eq. A2)
<i>t</i>	time, s

t	t -distribution for confidence interval estimation, a statistical term (Eq. A5)
T	temperature, °C
x	mean value of x , a statistical term (Eq. A5)
Y	DSC curve difference between empty container and sample/reference
σ	standard deviation, a statistical term

Glossary

Deodorization – A treatment process for oils and fats at high temperature (200–250°C) and low pressure (0.1–1 mm Hg); it is an important step in the refining of oils and fats, resulting in the removal of volatile and odorous compounds, including fatty acids, monoacylglycerols and oxidation products.

Oil refining – Industrial technology to obtain edible oils from crude palm oil through processing steps such as degumming, neutralization, bleaching and deodorization.

Palm oil – The oil palm produces two major vegetable oils. One comes from its fleshy endosperm (palm oil) and the second, of different character, from the kernels (palm oil kernel).

Triglycerides – A lipid class based on glycerol esterified to three fatty acids. These are the major compounds in all fats and oils and the most abundant type of lipid structures.

References

- 1 H. Suzuki and B. Wunderlich, *J. Thermal Anal.*, 29 (1984) 1369.
- 2 T. Hatakeyama, H. Kanetsuna and S. Ichihara, *Thermochim. Acta*, 146 (1989) 311.
- 3 W. P. Brennan, B. Miller and J. C. Whitwell, *Ind. Eng. Fundamentals*, 8 (1969) 314.
- 4 Transaction Report, Fujimoto, Nishimoto, 'Dai 23 Kai Netsu Sokutei Toronkai Koen Yoshiyu' p. 110, translated by Tomoko Ozaki, Seiko Inst., Japan.
- 5 Y. Ichimura, R. Kinoshita, Y. Teramoto and H. Yoshida, *Thermochim. Acta*, 179 (1991) 117.
- 6 G. Chataing and J. M. Vergnaud, *Thermochim. Acta*, 94 (1985) 379.
- 7 J. G. Phillips and M. M. Mattamal, *J. Chem. Eng. Data*, 21 (1976) 228.
- 8 J. W. Hampson and H. L. Rothbart, *JAOCS*, 60 (1983) 1102.
- 9 K. I. Xichiro, I. Ichi and J. Jin, *Netsu Sokutei*, 13 (1986) 17.
- 10 J. Schawe and C. Schick, *Thermochim. Acta* 186 (1991) 335.
- 11 *Thermal Analysis System Operation Manual*, Seiko DSC220, Appendix Section, Seiko Instrument Inc., Scientific Instrument Division, August, Japan 1989.
- 12 T. H. Gow, *Guide to Modern Methods of Instrumental Analysis*, 1st. Ed., Wiley Interscience, New York 1972.
- 13 D. C. Montgomery, *Design and Analysis of Experiments*, 2nd. Ed., John Wiley and Sons, New York 1984.

Appendix

Statistical Analysis of Experimental Data [13]

The specific heat capacity of trilaurin under improved conditions of scan rate = 17 deg·min⁻¹, sample mass = 21 mg and nitrogen flow rate = 50 ml·min⁻¹ is taken as an example. The number of data points for the four experimental runs is $n = 137$. The best fit to the experimental data points using the least square method is represented by:

$$C_p(\text{J/g}\cdot\text{deg}) = 0.002442 T (\text{°C}) + 1.89905 \quad (\text{A1})$$

for the temperature range 55 to 170°C.

For this analysis $SS_e = 0.0175$, where SS_e is calculated from

$$SS_e = SS_{pe} + SS_{lof} \quad (\text{A2})$$

The sum of squares of pure error, $SS_{pe} = 0.01616$, from

$$SS_{pe} = \sum_{i=1}^m \sum_{u=1}^{n_i} (y_{iu} - y_i)^2 \quad (\text{A3})$$

Since, $SS_{lof} = SS_e - SS_{pe}$, $SS_{lof} = 0.0131$.

The degree of freedom for SS_e is $n - 2 = 135$, and for $SS_{pe} = 101$, and therefore the degree of freedom for $SS_{lof} = 34$.

The mean square error is given by $MS_{pe} = SS_{pe}/n - 2 = 0.00016$ and $MS_{lof} = SS_{lof}/34 = 0.00038$.

From these calculations, the F -test from

$$F_o = MS_{lof} / MS_{pe} \quad (\text{A4})$$

gives $F_o = 0.2410$. This is less than the critical F -value of 1.00. The adequacy of the model is therefore proven.

The standard deviation σ of the data points is 0.0797.

As an illustration, the 95% confidence interval for β_1 for the data at $T = 70^\circ\text{C}$ is 2.0699 ± 0.0036 (J/g·deg) using

$$y_o \pm t_{\alpha/2, n-2} \sqrt{MS_e(1/n + (x - x_o)^2/S_{xx})} \quad (\text{A5})$$

Zusammenfassung — Unter Einsatz von Wärmefluß-DSC mit verbesserten Operationsbedingungen kann man reproduzierbare spezifische Wärmekapazitäten von Triglyceriden erhalten. Die verbesserten Operationsbedingungen, wie zum Beispiel die Scanning-Geschwindigkeit, die Pro-

benmasse und die Atmosphäre in der DSC-Kammer wurden anhand einer statistischen Auswertung der experimentellen Daten von Trilaurin als Probe festgestellt. Die spezifischen Wärmekapazitätswerte von Trilaurin wurden mit Werten verglichen, die mit Hilfe von Näherungsmethoden errechnet wurden. Die Genauigkeit der an Trilaurin unter diesen Bedingungen gemessenen spezifischen Wärmekapazität lag innerhalb $\pm 1\%$.